



Electrolux
SERVICE

When ordering spare parts always state:

MODEL · QUANTITY · PART NUMBER · DESCRIPTION

For electric details also:

VOLTAGE · WATTAGE

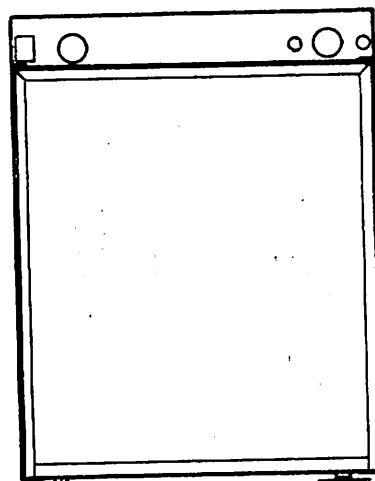
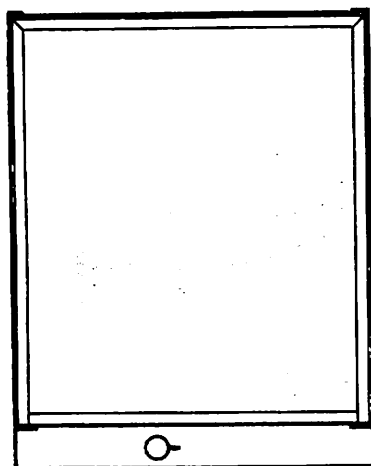
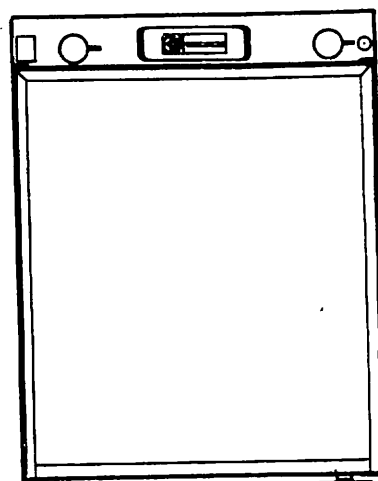
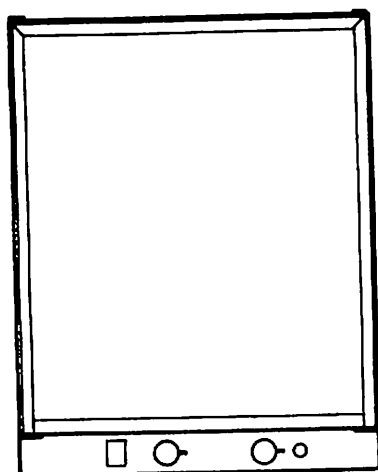

Product No.

926 55 xx

(see page 2)

REFRIGERATORS

RA 200

RA 201, A

RM 200, A, B, F, S

RM 201, A

RM 203

A68K-GE

A680 EGO, A680 EGU

A680A EGO, A680A EGU

SPARE PARTS LIST

Replaces edition 3, publ.No. 5255
and edition 1, RM203, publ.No. 5530

Group KA1

Edition **4**

Publication No.

599 10 70-75/5

-E/T/F/Sp/S
Service

February 1984

© ELECTROLUX

DES

SERVICE MARKETING DEPARTMENT

Produkt Nr.	Modell	Armaturo				Volt	Gashermostat	Gasregel	Zündsicherung	Markt
		Oben liegende	Unten liegende	Gas	El.					
926 55 11	RM200	x	-	x	x	12/220	-	-	-	
926 55 13	RM200	x	-	x	x	220	-	x	x	Schweden
926 55 17	RM200	x	-	x	-	-	-	x	x	Deutschland
926 55 21	RM200	x	-	x	x	12/220	-	x	x	Österreich
926 55 21	A68K-GE	x	-	x	x	12/220	-	-	-	
926 55 25	RM200	x	-	x	x	12/220	-	x	x	Frankreich
926 55 26	RM200	x	-	x	x	12/220	-	x	x	Schweiz
926 55 31	A680 EGO	x	-	x	x	12/220	-	x	x	Italien
926 55 32	A680 EGO	x	-	x	x	12/220	-	x	x	Frankreich
926 55 33	A680 EGU	-	x	x	x	12/220	-	x	x	Italien
926 55 34	A680 EGU	-	x	x	x	12/220	-	x	x	Frankreich
926 55 41	RM200A	x	-	x	x	12/220	-	x	x	
926 55 42	RM200A	x	-	x	x	220	-	x	x	Schweden
926 55 43	RM200A	x	-	x	x	220	-	x	x	
926 55 44	RM200A	x	-	x	x	12/220	-	-	-	
926 55 45	RM200A	x	-	x	x	12/220	-	x	x	Schweiz
926 55 48	RM200A	x	-	x	x	12/220	-	x	x	
926 55 49	A680 EGC	x	-	x	x	12/220	-	x	x	Italien
926 55 49	RM200A	x	-	x	x	12/220	-	x	x	Italien
926 55 50	A680A EGO	x	-	x	x	12/220	-	x	x	Frankreich
926 55 51	A680A EGU	-	x	x	x	12/220	-	x	x	Italien
926 55 52	A680A EGU	-	x	x	x	12/220	-	x	x	Frankreich
926 55 53	RM201	-	x	x	x	12/220	-	x	x	Deutschland
926 55 55	RM201A	-	x	x	x	12/220	-	x	x	Italien
926 55 56	RM201A	-	x	x	x	12/220	-	x	x	Österreich
926 55 57	RM201A	-	x	x	x	12/220	-	x	x	Schweiz
926 55 58	RM200	x	-	x	x	12/220	-	x	x	
926 55 59	RM200	-	x	x	x	12/220	x	-	-	
926 55 61	RA201	-	x	-	x	12/220	-	-	-	Deutschland
926 55 64	RM200A	x	-	x	x	12/220	-	x	x	Holland, Belgien
926 55 65	RM200A	x	-	x	x	12/220	-	x	x	Italien, Spanien
926 55 66	RM200S	-	-	x	x	12/220	-	x	x	Deutschland
926 55 69	RM203	-	-	x	x	12/220	x	-	x	Frankreich
926 55 71	RM200B	-	-	x	x	12/220	-	x	x	Deutschland, Österreich
926 55 74	RM200B	-	-	x	x	12/220	-	x	x	Belgien, Holland
926 55 75	RM200B	-	-	x	x	12/220	-	x	x	Italien, Spanien
926 55 76	RM200B	-	-	x	x	12/220	-	x	x	Skandinavien, Holland
926 55 77	RM200B	-	-	x	x	12/220	-	x	x	Belgien, Holland
926 55 80	RM201A	-	x	x	x	12/220	-	x	x	Holland
926 55 81	A680A EGU	-	x	x	x	12/220	-	x	x	
926 55 84	RM201A	-	x	x	x	12/220	-	x	x	Deutschland
926 55 85	RA201A	-	x	-	x	12/220	-	-	-	Deutschland
926 55 88	RM200F	x	-	x	x	12/220	-	x	x	Frankreich
926 55 90	RA200	-	x	-	x	220	-	-	-	Deutschland, Österreich
926 55 91	RA200	-	x	-	x	220	-	-	-	Deutschland, Österreich
926 55 92	RM200A	x	-	x	x	12/220	x	-	x	Schweden, Norwegen
926 55 94	RM200B	-	-	x	x	12/220	-	x	x	Schweiz
926 55 99	RM203	-	-	x	x	12/220	x	-	x	Deutschland, Österreich

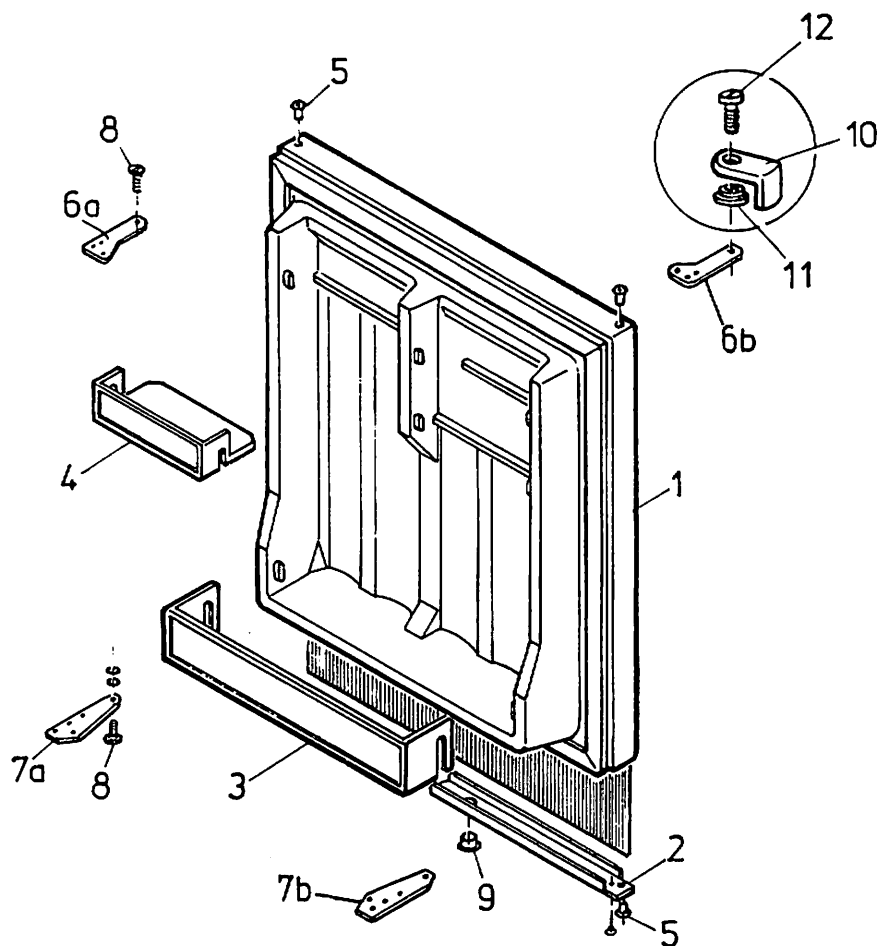

Pos. Nr.	Teil Nr.	Benennung	Nr. des Herstellers
1	292 35 24-00/9	Tür, kompl., geschäumt	04305
2	292 35 25-00/6	Leiste unten	04138
3	292 33 36-00/8	Flaschenhalter	03466
4	292 33 37-00/6	Halterung für Eier	03467
5	292 32 90-00/7	Buchse	03624
6a	292 35 26-00/4	Scharnier oben rechts	04077
6b	292 36 22-00/1	Scharnier oben links	04078
7a	292 35 27-00/2	Scharnier unten rechts	04075
7b	292 36 21-00/3	Scharnier unten links	04076
8	292 30 05-00/9	Scharnierschraube	91334
9	292 31 71-00/9	Stopfen	06892
10	292 34 27-00/5	Türverriegelung	03959
11	292 34 28-00/3	Hülse	03960
12	292 34 29-00/1	Schraube M 6x6	06947

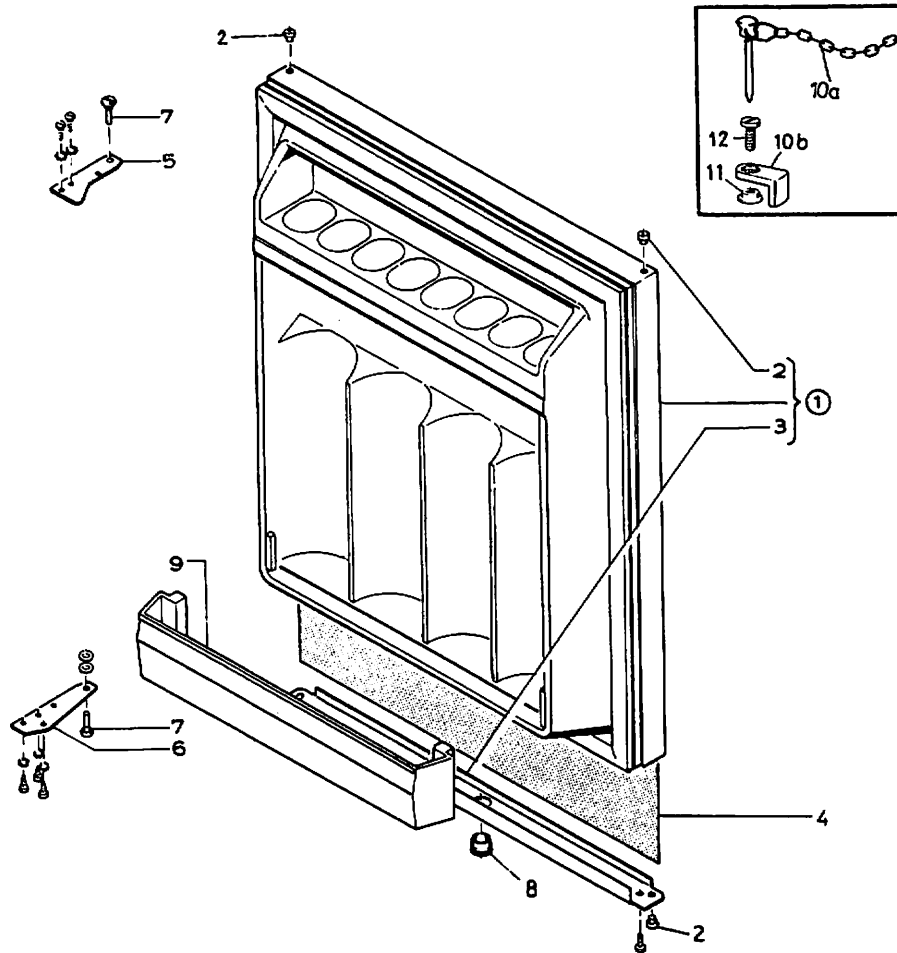

A = RA200
 B = RM200B, RM200F, RM200S, RA201, RA201A, RM201A
 C = RM200, RM200A, RM200F, RM201, RA201A, RM201A, RM203,
 A68K-GE, A68OEGO, A68OEGU, A68OA EGO, A68OA EGU

Pos. Nr.	Teil Nr.	Benennung	Nr. des Herstellers
1	292 31 67-00/7	- - C Tür, kompl., geschäumt	03297
	292 36 30-00/4	A B - Tür, kompl.	04145
2	292 30 01-00/8	- - C . Scharnierbuchse	90987
	292 32 90-00/7	A B - . Scharnierbuchse	03624
3	292 31 70-00/1	- - C . Türleiste, unten	03295
	292 35 25-00/6	A B - . Türleiste, unten	04138
4	292 31 99-00/0	A B C Dekorplatte	06905
5	292 32 92-00/3	- - C Scharnier, oben rechts und links	03559
	292 35 26-00/4	A B - Scharnier, oben, rechts	04077
	292 36 22-00/1	A B - Scharnier, oben, links	04078
6	292 30 04-00/2	- - C Scharnier, unten rechts und links	02880
	292 35 27-00/2	A B - Scharnier, unten, rechts	04075
	292 36 21-00/3	A B - Scharnier, unten, links	04076
7	292 30 05-00/9	A B C Scharnierschraube	91334
	292 31 71-00/9	A B C Stopfen	06892
9	292 31 68-00/5	A B C Flaschenhalter	03299
10a	292 31 72-00/7	- - C Sicherungskette mit Stift (nicht RM203)	06893
10b	292 34 27-00/5	- B C Türverriegelung	03959
11	292 34 28-00/3	- B C Hülse	03960
12	292 34 29-00/1	- B C Schraube	06947

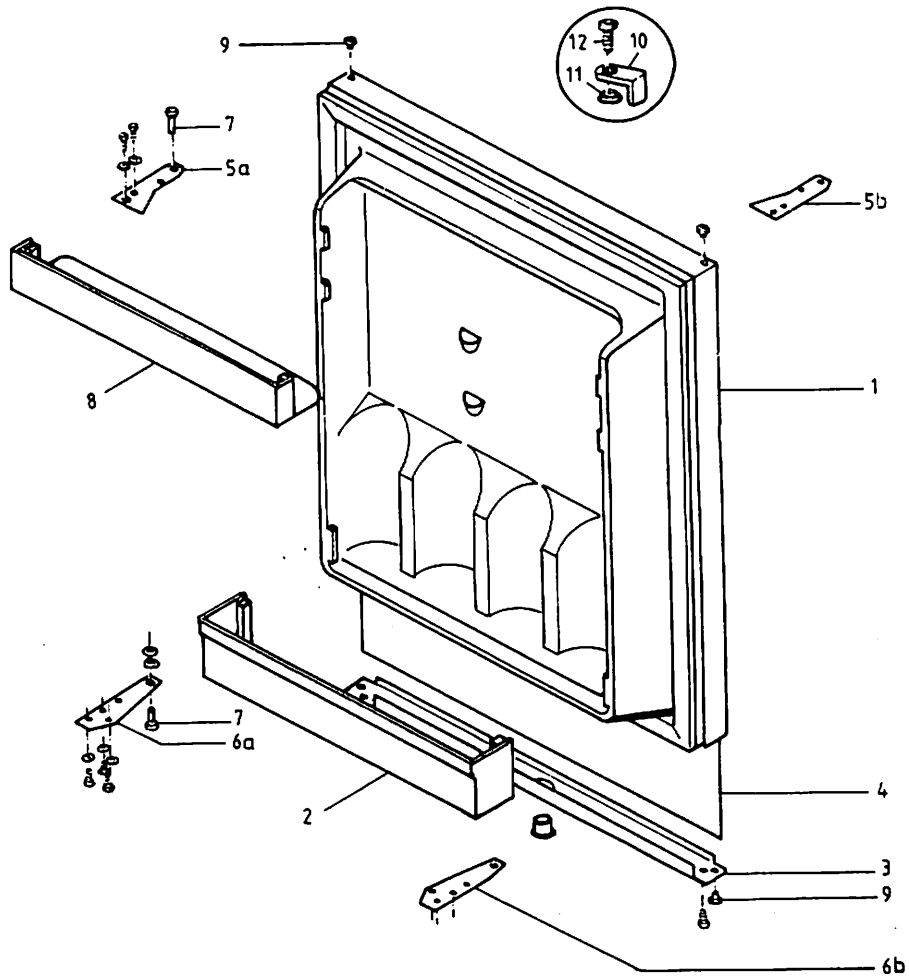

Pos. Nr.	Teil Nr.	Benennung	Nr. des Herstellers
1	292 36 61-00/9	Tür kpl. geschäumt	04489
2	292 31 68-00/5	Flaschenhalter	04486
3	292 35 25-00/6	Türleiste unten	04138
4	292 31 99-00/0	Dekorplatte	06905
5a	292 35 26-00/4	Scharnier, oben rechts	04077
5b	292 36 22-00/1	Scharnier, oben links	04078
6a	292 35 27-00/2	Scharnier, unten rechts	04075
6b	292 36 21-00/3	Scharnier unten links	04076
7	292 30 05-00/9	Scharnierschraube	91334
8	292 36 62-00/7	Etagere oben	04487
9	292 32 90-00/7	Scharnierbuchse	03624
10	292 34 27-00/5	Türverriegelung	03959
11	292 34 28-00/3	Hülse	03960
12	292 34 29-00/1	Schraube	06947

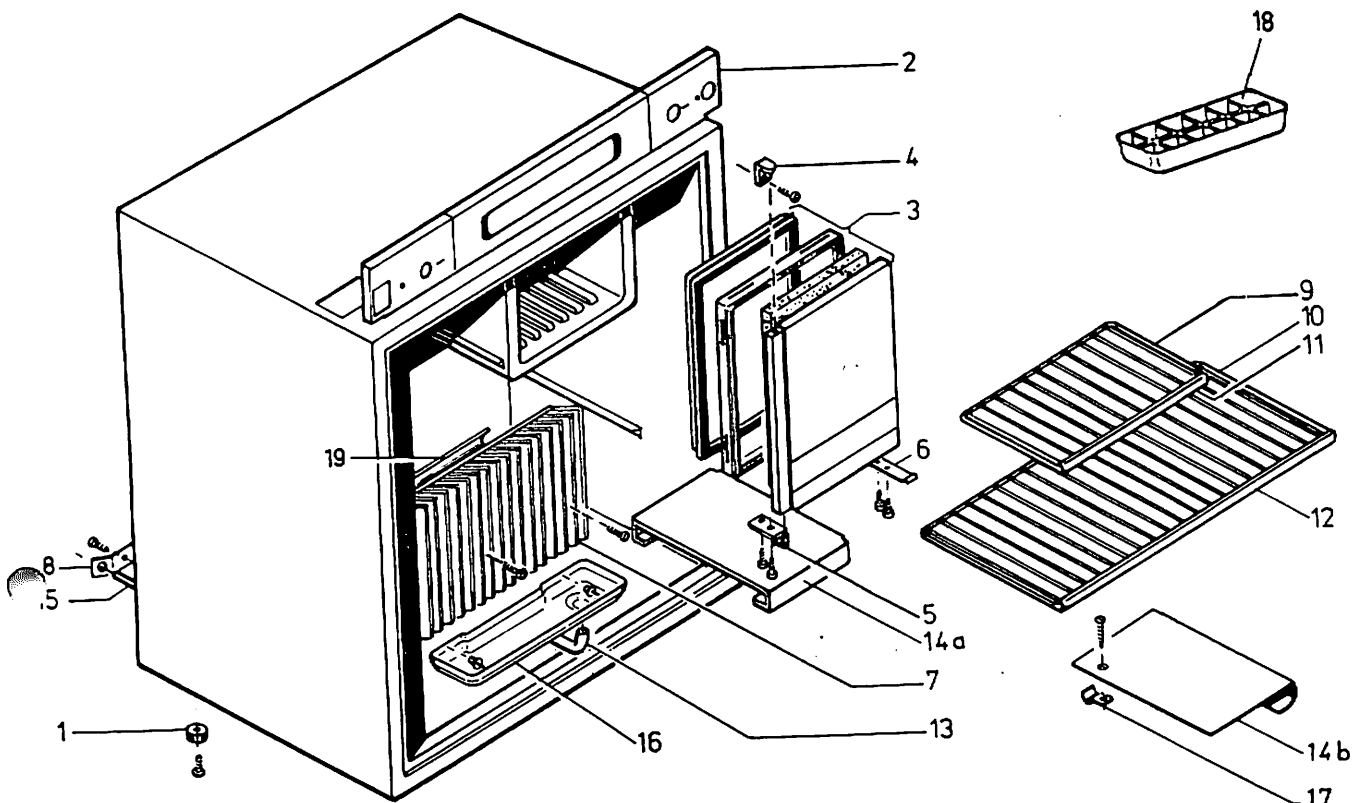

A = RA200
B = RM200A, RM200B, RM200S, A680A EGO
C = RM200, A680 EGO, A68K-GE
D = RM203

Pos. Nr	Teil Nr.	Benennung	Nr. des Herstellers
1	292 30 14-00/1	A B C D Fuss	90054
2	292 31 51-00/1	- B C - Bedienungsblende für Schalter 1 - Pol.	03322
	292 35 22-00/3	- - - D Bedienungsblende für Schalter 1 - Pol.	04292
	292 36 24-00/7	- B - - Bedienungsblende für Schalter 2x1 Pol.	04203
3	292 33 21-00/0	A B C D Frosterfachtür, braun für Service	03616
4	292 31 53-00/7	A B C D Scharnier, oben	06886
5	292 33 22-00/8	A B C D Scharnier, unten für Service	91598
6	292 31 55-00/2	A B C D Haltefeder	91532
7	(292 31 56-00/0)	A B C D Nachverdampfer	03317
8	292 31 65-00/1	- B C D Haltefeder	91351
9	292 33 23-00/6	A B C D Tragrost, oben. Weiss	03801
10	292 33 24-00/4	A B C D Tragrost, unten. Weiss	03802
11	(292 31 60-00/2)	A B C D Zierleiste, oben	91510
12	(292 31 61-00/0)	A B C D Zierleiste, unten	91509
13	(292 31 62-00/8)	A B C - Ablaufschlauch	06889
14a	292 33 25-00/1	- B - D Eisschalenauflage	03692
14b	(292 31 63-00/6)	A - C - Eisschalenauflage	03270
15	292 31 64-00/4	- B C D Lichtleitstab	91512
16	(292 31 57-00/8)	A - C - Tropfschale	03323
17	292 31 66-00/9	A - C - Haltetasche	03333
18	292 20 21-01/5	- - - D Eisschale	
19	(292 35 58-00/7)	A B C D Scheibe für Nachverdampfer	03938

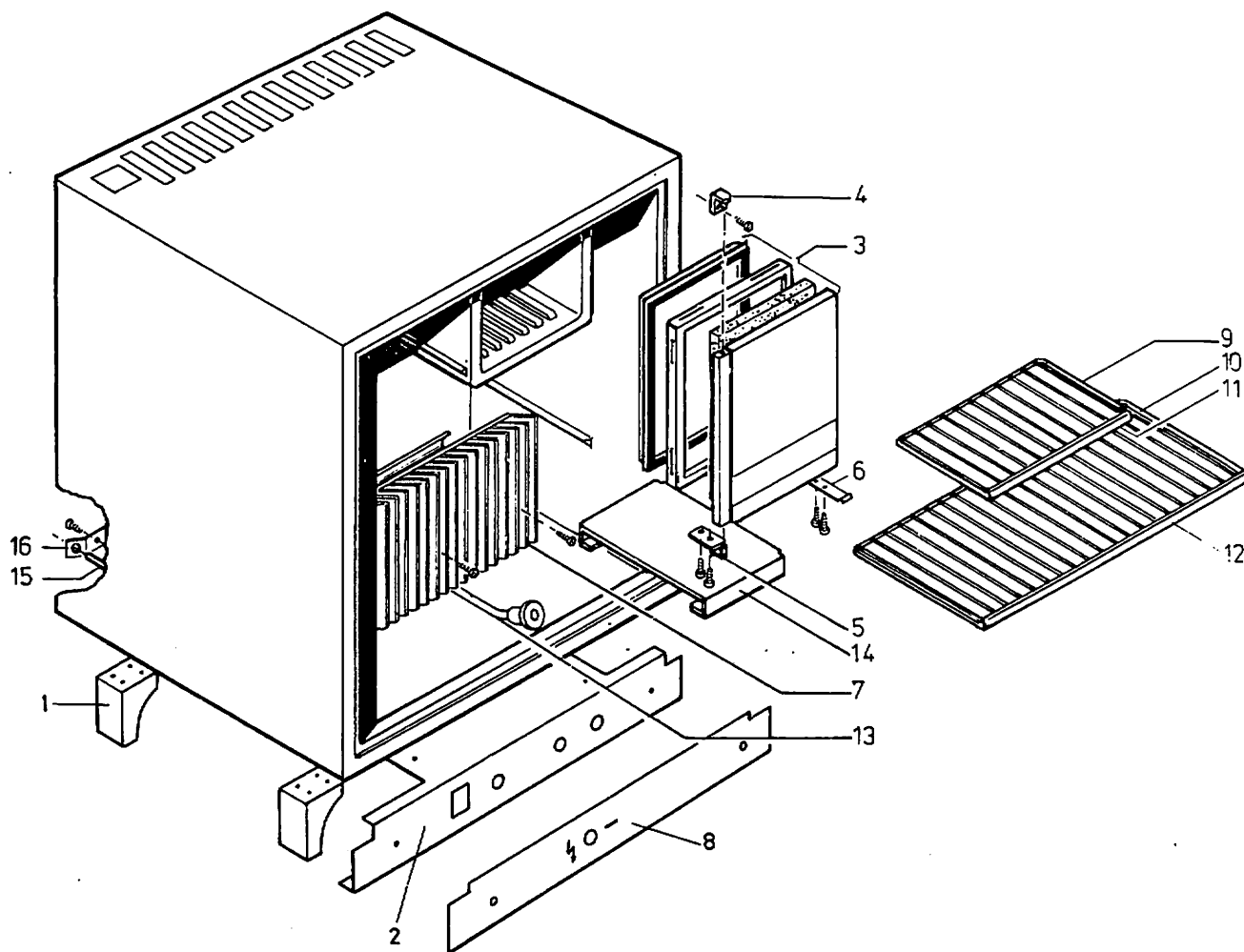

A = RA201, RA201A
 B = RM201, RM201A

Pos. Nr.	Teil Nr.	Benennung	Nr. des Herstellers
1	292 33 26-00/9	A B Fuss	91642
2	292 33 27-00/7	A B Bedienungsblende	03723
3	292 33 21-00/0	A B Frosterfachtür, braun	03616
4	292 31 53-00/7	A B Scharnier, oben	06886
5	292 33 22-00/8	A B Scharnier, unten	91598
6	292 31 55-00/2	A B Haltefeder	91532
7	292 31 56-00/0	A B Nachverdampfer	03317
8	292 33 2R-00/5	A - Bedienungsschild für el. Modell	03823
	292 36 27-00/0	- B Bedienungsschild für el. + gas Modell	03770
9	292 33 23-00/6	A B Tragrost, oben	03801
10	292 33 24-00/4	A B Tragrost, unten	03802
11	292 31 60-00/2	A B Zierleiste	91510
12	292 31 61-00/0	A B Zierleiste	91509
13	292 31 62-00/8	A B Ablaufschlauch	06889
14	292 33 25-00/1	A B Eisschalenauflage	03692
15	292 31 64-00/4	- B Lichtleitstab	91512
16	292 31 65-00/1	- B Haltefeder	91351

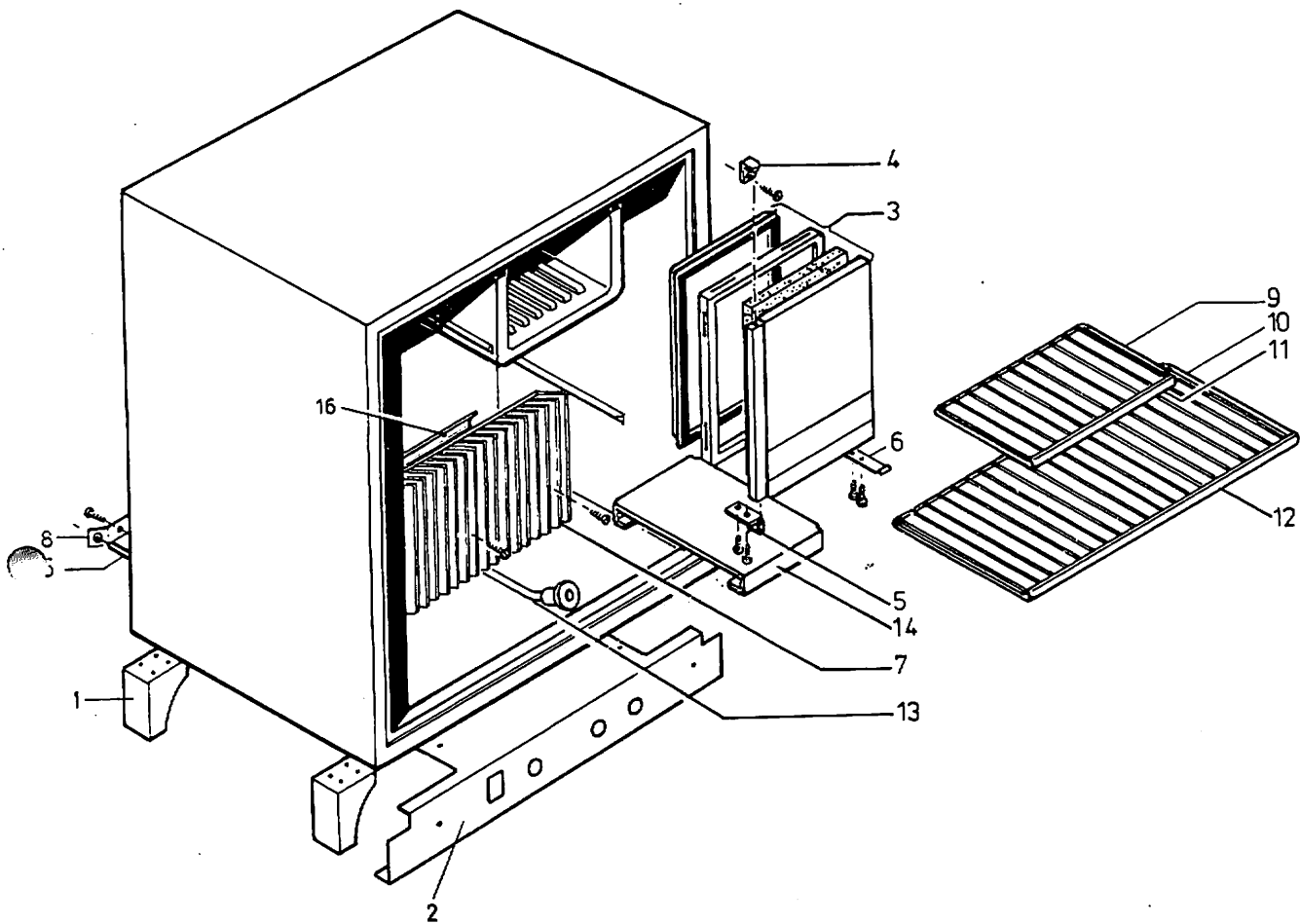

A = RM200F
B = A680EGU, A680A EGU

Pos. Nr.	Teil Nr.	Benennung	Nr. des Herstellers
1	292 33 26-00/9	A B Fuss	91642
2	292 33 27-00/7	A B Bedienungsblende	03723
3	292 33 21-00/0	A B Frosterfachtür, braun	03616
4	292 31 53-00/7	A B Scharnier, oben	06886
5	292 33 22-00/8	A B Scharnier, unten	91598
6	292 31 55-00/2	A B Haltefeder	91532
7	292 31 56-00/0	A B Nachverdampfer	03317
8	292 31 65-00/1	A B Haltefeder	91351
9	292 33 23-00/6	A B Tragrost, oben	03801
10	292 33 24-00/4	- B Tragrost, unten	03802
	292 34 53-00/1	A - Tragrost, unten	03926
11	292 31 60-00/2	A B Zierleiste	91510
12	292 31 61-00/0	A B Zierleiste	91509
13	292 31 62-00/8	A B Ablaufschlauch	06889
14	292 33 25-00/1	A B Eisschalenauflage	03692
	292 31 64-00/4	- B Lichtleitstab	91512
15	292 36 28-00/8	A - Lichtleitstab	03924
16	(292 35 58-00/7)	A - Scheibe für Nachverdampfer	03938

Schaltbild

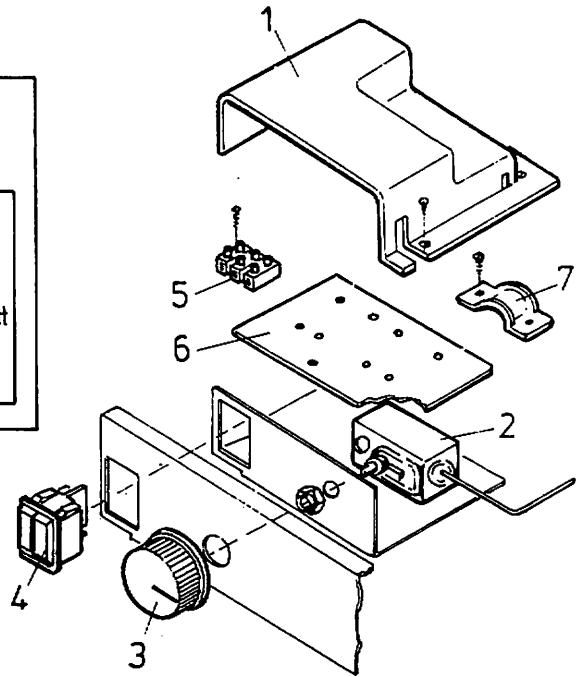
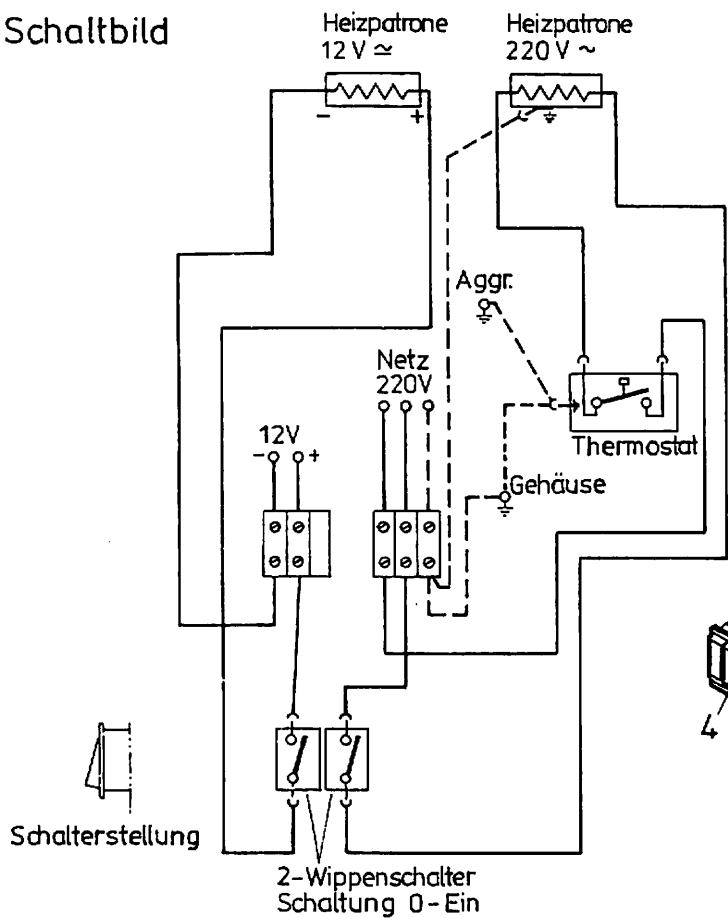

Pos. Nr.	Teil-Nr.	Benennung	Nr. des Herstellers
1	292 30 28-00/1	Abdeckung	03230
2	292 30 37-00/2	Thermostat	06829
3	292 34 68-00/9	Drehknopf f. Therm. schwarz	91829
4	292 34 65-00/5	2x1-poliger Ausschalter	91826
5	292 34 66-00/3	Klemmleiste 3-polig	07000
6	292 34 67-00/1	Isolierplatte	91824
7	292 30 58-00/8	Iso - Schelle - Oberteil	91739(06865)

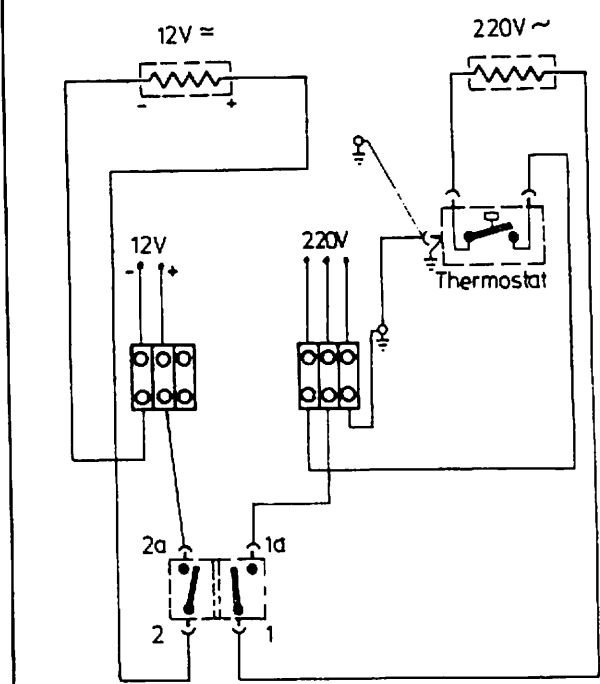
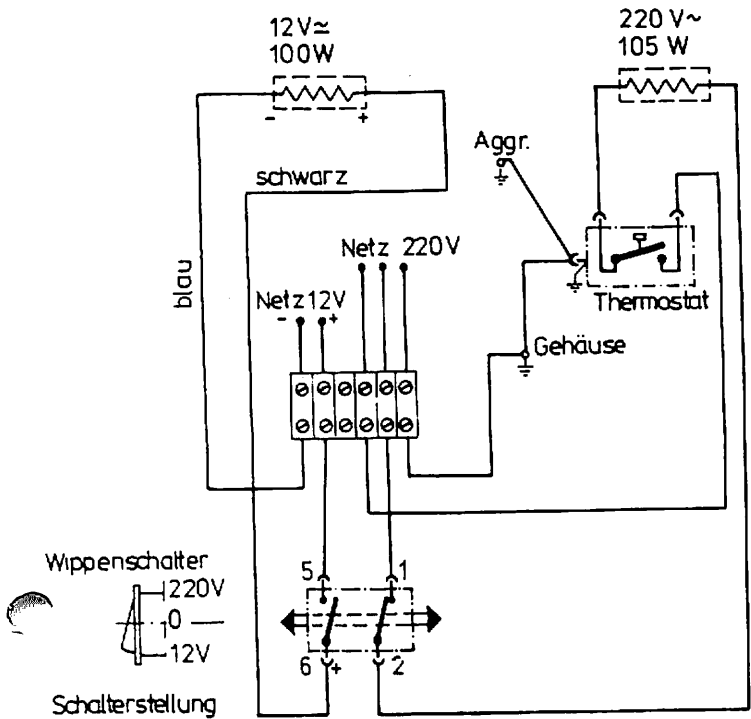

RM200A, RM200B, RM200S, RM300

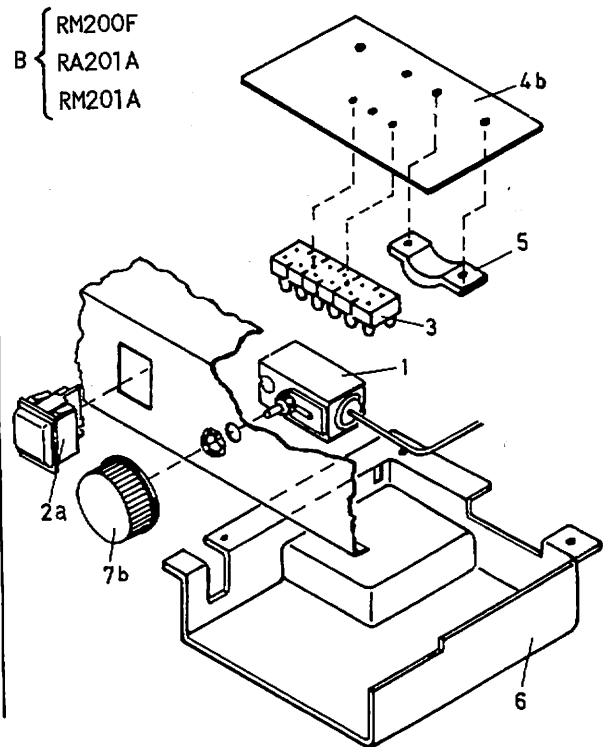
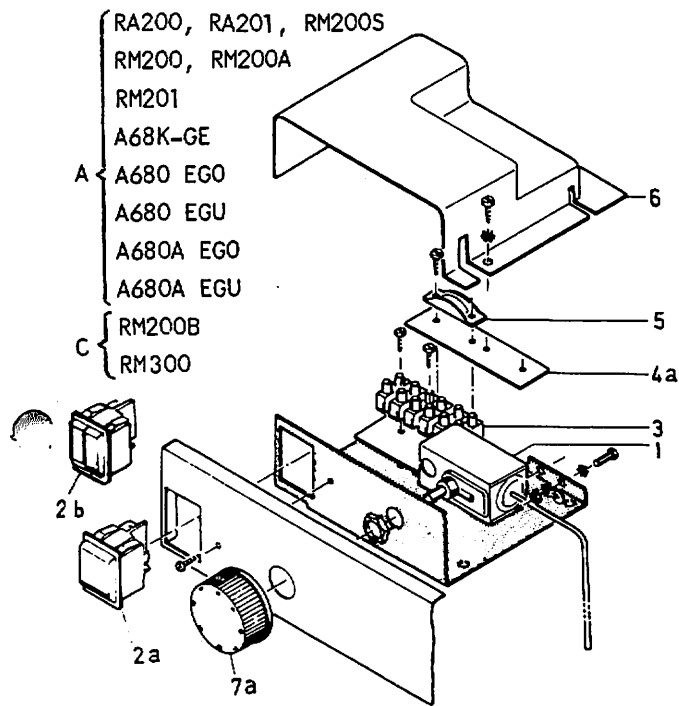

Pos. Nr.	Teil Nr.	Benennung	Nr. des Herstellers
1	(292 30 37-00/2)	A B C Thermostat Kann in Service durch 290 07 02-01/6 ersetzt werden.	06829
2a	292 31 77-00/6	A B - Schalter, schwarz	06890
2b	292 34 65-00/5	A - C Ausschalter 2x1-poliger (RM200A)	91826
3	(292 30 30-00/7)	A B - Klemmleiste	06790
	(292 34 66-00/3)	- - C Klemmleiste	07000
4a	(292 31 78-00/4)	A - Unterlegplatte	91021
4b	(292 33 84-00/8)	- B - Unterlegplatte	03530
	(292 34 67-00/1)	- - C Unterlegplatte	06865
5	292 30 58-00/8	A B C Zugentlastungsschelle	06865
6	292 30 28-00/1	A B C Abdeckkappe	03793
7a	292 31 80-00/0	A - C Drehknopf Ø 40 mm	91438
7b	292 33 29-00/3	- B C Drehknopf Ø 30 mm	91664

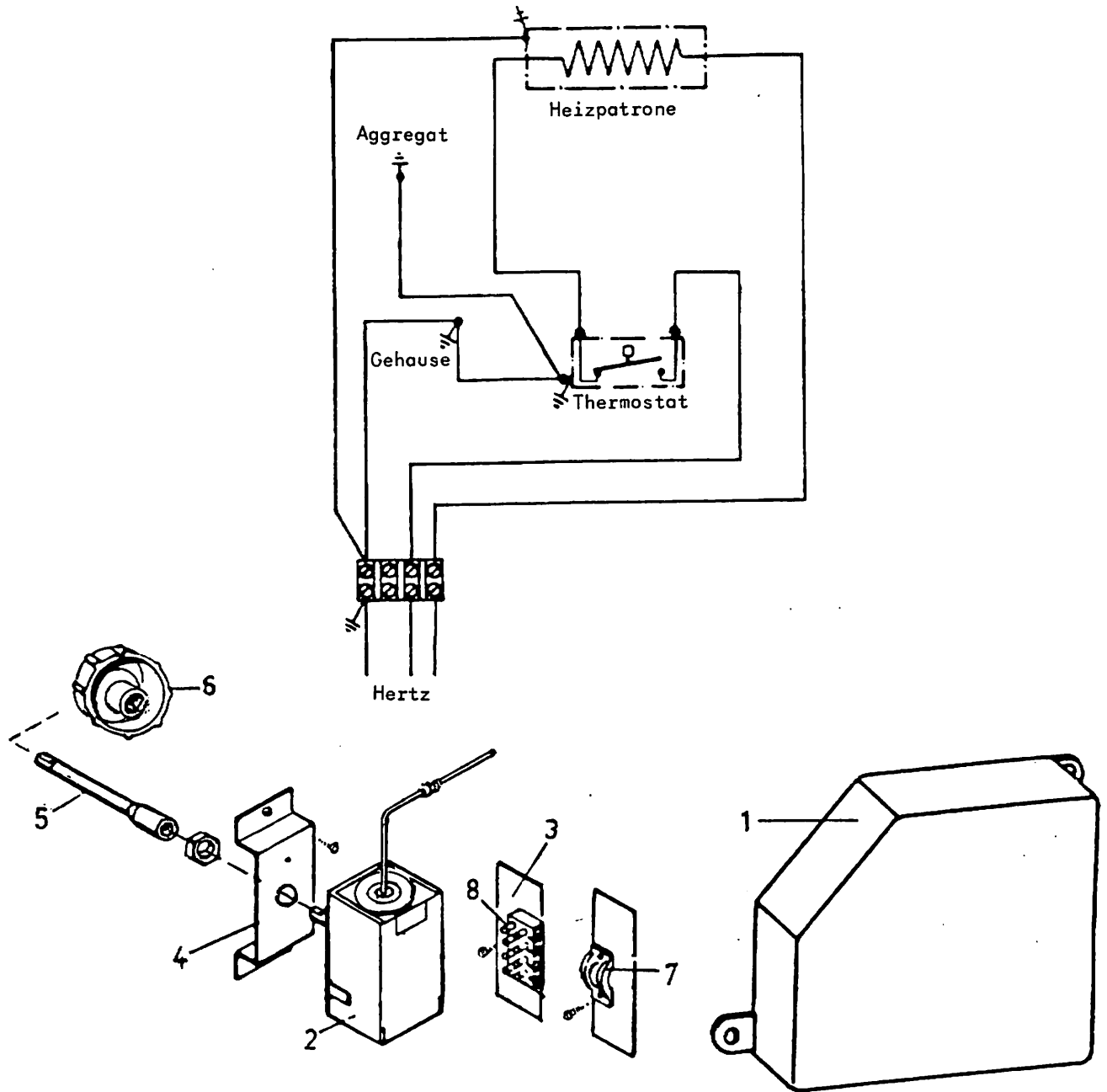

Pos. Nr.	Teil Nr.	Benennung	Nr. des Herstellers
1	292 36 29-00/6	Abdeckung für Elektroteile	03995
2	(292 30 37-00/2)	Thermostat Kann in Service durch 290 07 02-01/6 ersetzt werden.	06829
3	(292 31 78-00/4)	Isolierplatte	91021
4	(292 33 77-00/2)	Thermostatwinkel	03753
5	292 33 78-00/0	Achselverlängerung	03797
6	292 33 79-00/8	Drehknopf	03818
7	292 30 58-00/8	Zugentlastungsschelle	06865
8	(292 30 79-00/4)	Klemmleiste 4-polig	90105

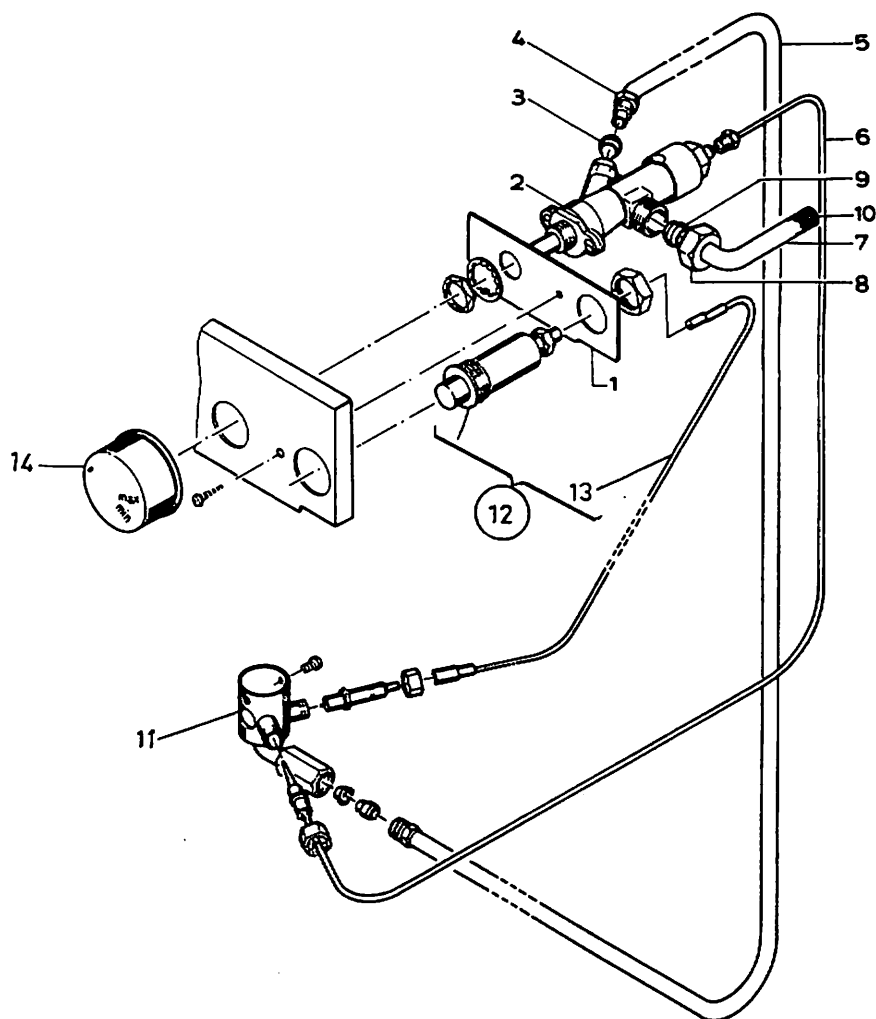

Pos. Nr.	Teil Nr.	Benennung	Nr. des Herstellers
1	292 31 84-00/2	Haltewinkel	03290
2	292 31 23-00/0	Sicherheitsschalter	06782
3	292 30 25-00/7	Doppelkegelring $\varnothing 6$	06832
4	292 31 85-00/9	Gewindebuchse M10x1	06879
5	292 31 86-00/7	Gaszuführrohr	03329
6	292 34 35-00/8	Thermoelement	06975
7	292 31 88-00/3	Gasanschlussrohr	03313
8	292 31 89-00/1	Oberwurfmutter M15x1	06767
9	292 31 90-00/9	Doppelkegelring $\varnothing 8$	06881
10	292 31 91-00/7	Filter	91218
11	-	Gasbrenner, kompl. (Kann in Service durch 292 34 37-01/2 ersetzt werden. Siehe Seite 15.)	
12	292 30 24-00/0	Piezozünder mit Zündkabel	06787
13	292 31 97-00/4	. Zündkabel	06888
14	292 31 96-00/6	Drehknopf	91437

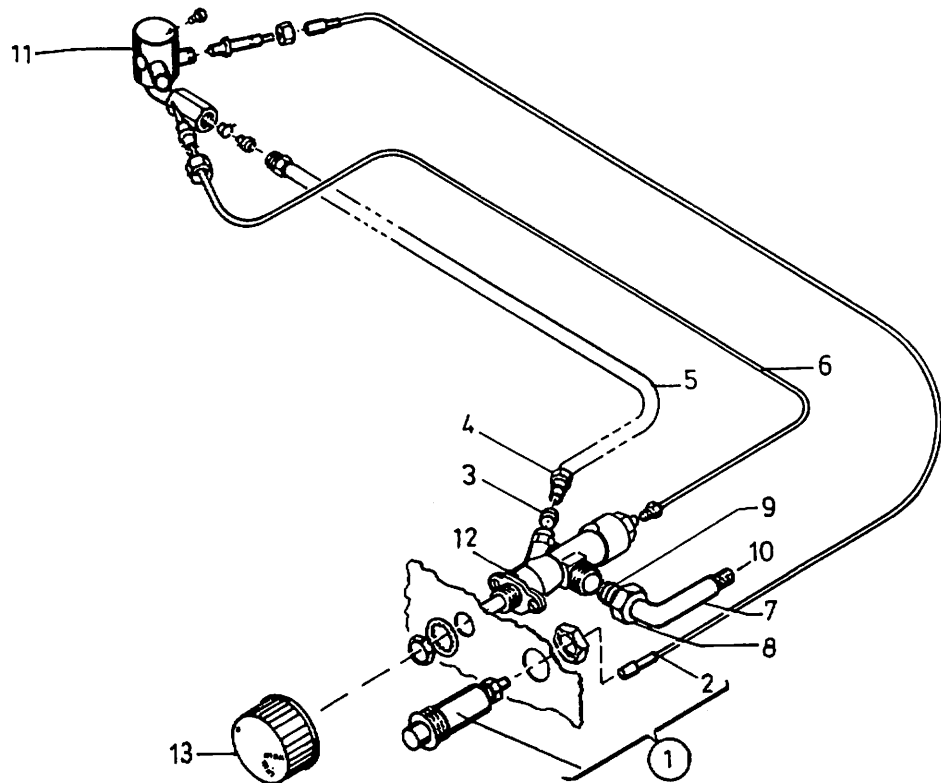

Pos. Nr.	Teil Nr.	Benennung	Nr. des Herstellers
1	292 30 24-00/0	Piezozünder mit Zündkabel	06787
2	292 31 97-00/4	. Zündkabel	06888
3	292 30 25-00/7	Doppelkegelring Ø 6	06832
4	292 31 85-00/9	Gewindebuchse M10x1	06879
5	292 33 32-00/7	Gaszuführrohr	03769
6	292 34 35-00/8	Thermoelement für Service	
7	292 33 33-00/5	Gasanschluss-Winkelstück	91673
8	292 31 89-00/1	Oberwurfmutter M15x1	06767
9	292 31 90-00/9	Doppelkegelring Ø 8	06881
10	292 31 91-00/7	Filter	91218
11	-	Gasbrenner, kompl. (Kann in Service durch 292 34 37-01/2 ersetzt werden. Siehe Seite 15.)	
12	292 31 23-00/0	Sicherheitsschalter	06782
13	292 33 34-00/3	Drehknopf	91665

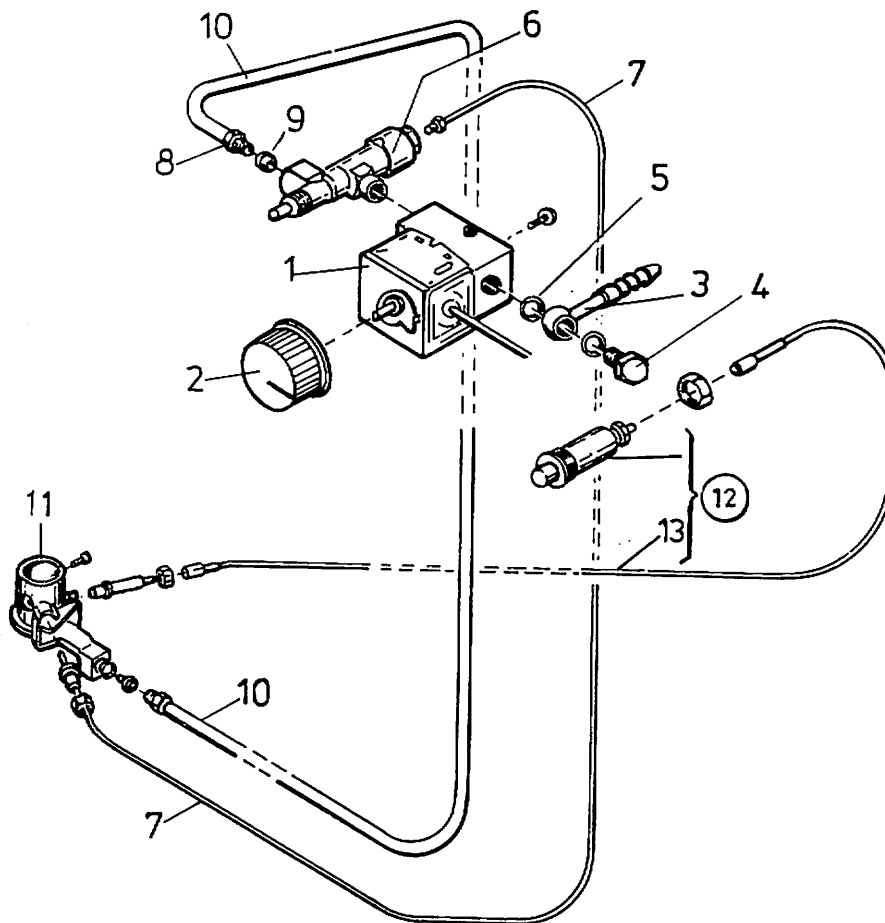

Pos. Nr.	Teil Nr.	Benennung	Nr. des Herstellers
1	290 12 36-12/1	Gasthermostat Ersetzt 292 30 16-00/6 in Service.	
2	292 30 17-00/4	Drehknopf für Service	91822
3	292 34 64-00/8	Gasanschlussstück Ersetzt 292 35 31-00/4 in Service.	
4	292 30 20-00/8	Gasfilter	91404
5	292 35 32-00/2	Dichtscheibe	07010
6	17 07 55-00/3	Zündericherung	06698
7	292 34 35-00/8	Thermoelement Ersetzt 292 31 87-00/5 in Service	
8	292 30 18-00/2	Einschraubmutter	91841 (06831)
9	292 30 25-00/7	Doppelkegelring Ø 6	91842 (06832)
10	292 30 21-00/6	Gaszuführrohr mit Isolierschlauch Ersetzt 292 35 33-00/0 in Service.	
11	-	Gasbrenner, kompl. Siehe Seite 15	
12	292 30 24-00/0	Piezozünder, kompl. mit Zündkabel 1100 mm lang	06787
13	292 31 97-00/4	. Zündkabel	06888

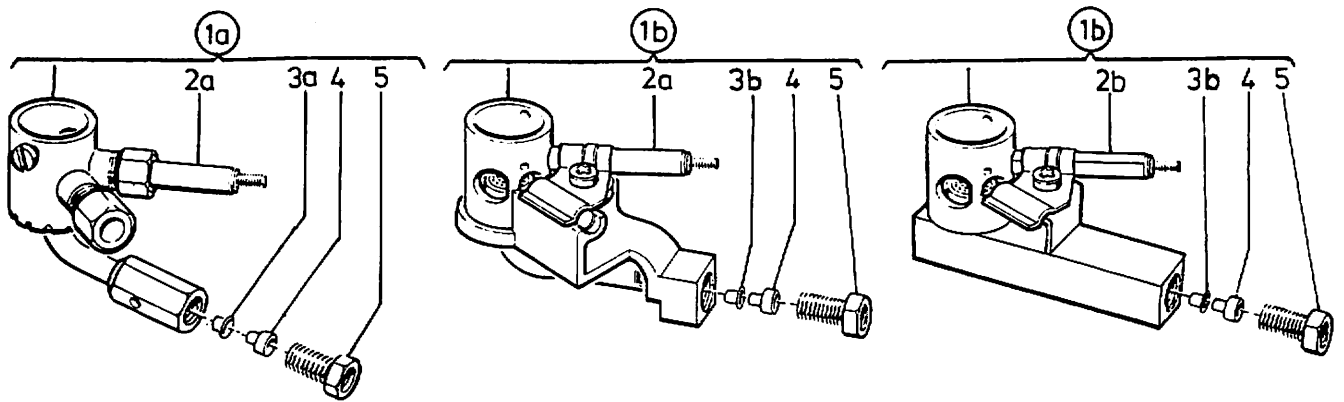

Pos. Nr.	Teil Nr.	Benennung	Nr. des Herstellers
1a	(292 31 92-00/5)	Brenner, kompl. Kann in Service durch Pos. 1b ersetzt werden	-
1b	292 34 30-00/9	Brenner, kompl., mit Düse 300 mm WS	-
	(292 34 31-00/7)	Brenner, kompl., mit Düse 500 mm WS	-
2a	292 30 23-00/2	. Zündkerze	06598
2b	292 36 26-00/2	. Zündkerze	07040
3a	292 20 33-01/0	. Düse Kz 24, 500 mm WS	
	292 20 33-03/6	. Düse Kz 21, 300 mm WS	
3b	292 20 33-04/4	. Düse Kz 45, 300 mm WS	-
	292 20 33-05/1	. Düse Kz 46, 500 mm WS	-
4	292 31 93-00/3	. Schneidring	06882
5	292 38 49-00/0	. Gewindebuchse M10x1	07923

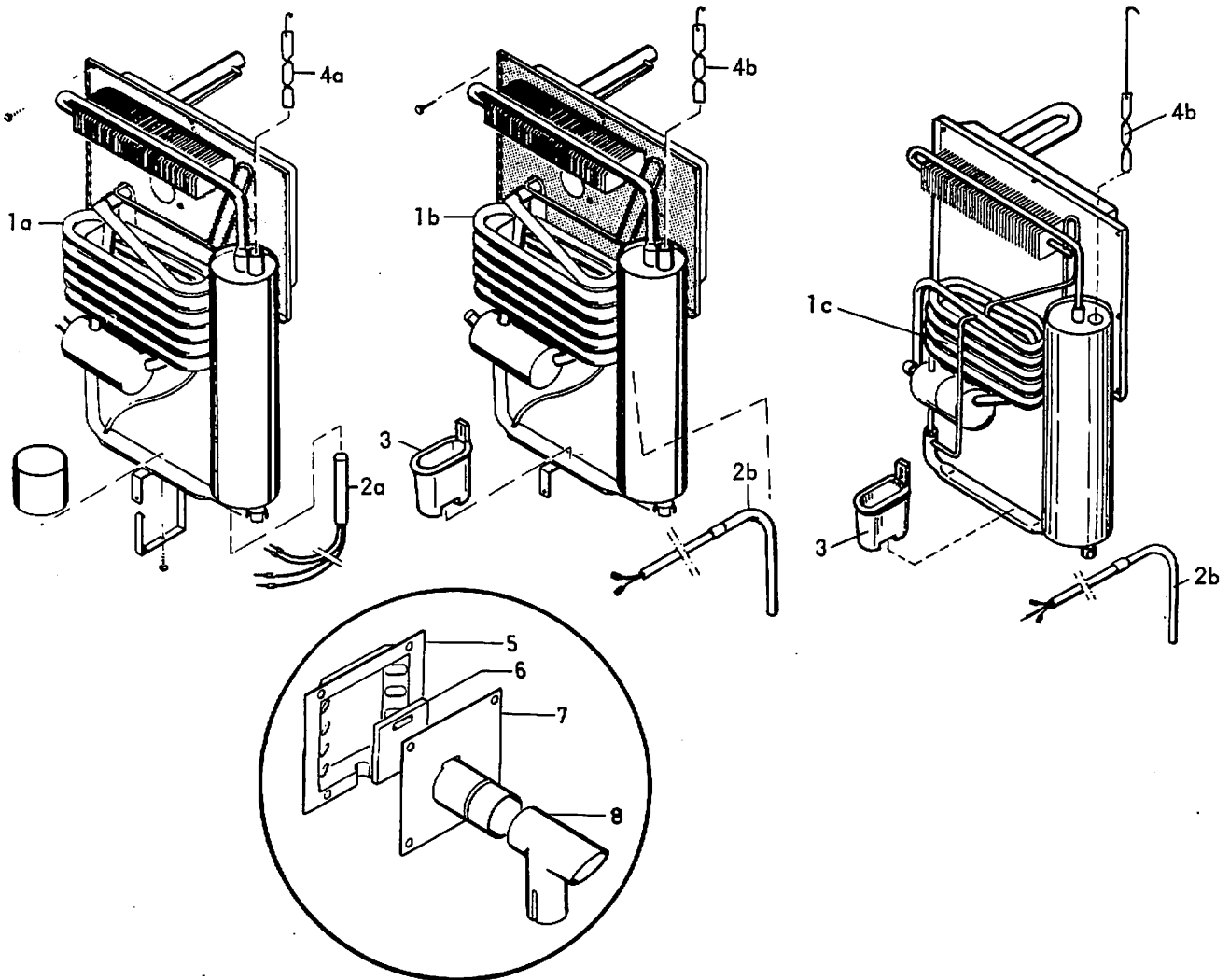

A = { RA200, RM200, RM200A, RM200F, RM200S, RA201, RA201A, RM201, RM201A
A68K-GE, A680 EGO, A680 EGU, A680A EGO, A680A EGU
B = RA200*, RM200B, RM200F*, RA201A*, RM201A*, (*Spätere Ausführung)
C = RM203

Pos. Nr.	Teil Nr.	Benennung	Nr. des Herstellers
1a	292 31 73-00/5	A - - Aggregat, kompl., eingeschäumt In Service durch 292 35 67-00/8 ersetzt.	03252
1b	(292 31 49-00/5)	A - - Aggregat, kompl., eingeschäumt. In Service durch 292 35 67-00/8 ersetzt.	03812
1c	292 35 67-00/8	- B - Aggregat, kompl.	07021
	292 35 28-00/0	- - C Aggregat, kompl.	04253
2a	292 31 81-00/8	A - - Stabheizpatrone 220/12V	91529
	292 31 83-00/4	A - - Stabheizpatrone 220V	91565
2b	292 33 30-00/1	A B - Rohrheizpatrone 220V, 105W	91656
	292 33 31-00/9	A B C Rohrheizpatrone 12V, 105W	91657
	292 35 29-00/8	- - C Rohrheizpatrone 220V, 95W	91906
	292 35 84-00/3	- B - Rohrheizpatrone 220V	91767
3	292 33 20-00/2	A B C Verdunstungsbehälter	91597
4a	292 31 76-00/8	A - - Wärmeverteiler	06891
4b	292 31 30-00/5	A B C Wärmeverteiler	-
5	292 30 34-00/9	A B C Abdeckblech	01761
6	292 30 35-00/6	A B C Gummidichtung	90974
7	292 30 32-00/3	A B C Abgasrohr	01978
8	292 31 48-00/7	A B - Rohr, lang	03813

Det.nr. Part No. Pièce No. Parte No.	Svenska Benämning	English Description	Français Désignation	Español Denominación
17 07 55-00/3	Tändsäkring	Safety valve	Soupape de surete	Valvula de seguridad
290 12 36-12/1	Gastermostat Ersätter Nr 292 30 16-00/6 i service	Gas thermostat Replaces no 292 30 16-00/6 in service	Thermostat de gaz Remplace No 292 30 16-00/6 en service	Termostato de gas Reemplaza No. 292 30 16-00/6 en servicio
292 20 21-01/5	Islåda	Ice-tray	Boîte à glace	Gaveta para hielo
292 20 33-01/0	Brännarmunstycke 24	Burner jet 24	Ejecteur de bruleur 24	Inyector de gas 24
292 20 33-03/6	Brännarmunstycke 21	Burner jet 21	Ejecteur de bruleur 21	Inyector de gas 21
292 20 33-04/4	Brännarmunstycke 45	Burner jet 45	Ejecteur de bruleur 45	Inyector de gas 45
292 20 33-05/1	Brännarmunstycke 46	Burner jet 46	Ejecteur de bruleur 46	Inyector de gas 46
292 30 01-00/8	Bussning	Bushing	Coussinet	Buje
292 30 04-00/2	Gångled, undre höger och vänster	Hinge, lower right and left	Charniere, inférieure droit et gauche	Bisagra inferior terretra y izquiereada
292 30 05-00/9	Gångledsskruv	Hinge screw	Vis	Tornillo
292 30 14-00/1	Fot	Foot	Pied	Pie
292 30 17-00/4	Termostattratt	Thermostat knob	Bouton de thermostat	Botón de termostato
292 30 18-00/2	Bussning	Bushing	Coussinet	Buje
292 30 20-00/8	Gasfilter	Gas filter	Filtre de gaz	Filtro de gas
292 30 21-00/6	Gastilloppsrör. Ersätter Nr 292 35 33-00/0 i service	Gas inlet pipe. Replaces No. 292 35 33-00/0 in service	Conduite de gaz. Remplace No. 292 35 33-00/0 en service	Tube alimentador. Reemplaza No. 292 35 33-00/0 en servicio
292 30 23-00/2	Tändstift	Spark plug	Bougie	Bujia
292 30 24-00/0	Gnisttändare kompl. med tändkabel	Lighter compl.with blasting cable	Allumeur compl. avec câble d'allumage	Encendedor compl. con cable detonador
292 30 25-00/7	Tätningring	Sealing ring	Anneau d'étanchéité	Anillo de junta
292 30 28-00/1	Kåpa	Cover	Enveloppe	Cubierta
(292 30 30-00/7)	Kopplingsplint	Terminal board	Plaque de connexion	Bloque de conexion
292 30 32-00/3	Avgaskanal, kompl.	Exhaust,compl.	Canal d'echappe,compl.	Canal de escape,compl.
292 30 34-00/9	Täckplåt	Cover plate	Place de recouvrement	Placa cubridora
292 30 35-00/6	Gummitätning	Rubber sealing	Joint de caoutchouc	Junta de goma
(292 30 37-00/2)	Termostat. Kan er- sättas av nr. 290 0702-01/6 i service	Thermostat. May be replaced by No. 290 0702-01/6 in service	Thermostat. Remplacable du No. 290 0702-01/6 en service	Termostato. Emplazamiento de 290 0702-01/6 en servicin
292 30 58-00/8	Avlastningsklamma	Anti-strain clip	Bride de câble	Mordaza
(292 30 79-00/4)	Kopplingsplint	Terminal board	Plaque de connexion	Bloque de conexion
292 31 23-00/0	Tändsäkring	Safety valve	Soupape de surete	Valvula de seguridad
292 31 30-00/5	Lågspridare	Flue baffle	Distributeur de chaleur	Distribución de calor
292 31 48-00/7	Rör	Tube	Tube	Tube
(292 31 49-00/5)	Aggregat, kompl. Ersatt av nr 292 35 67-00/8 i service.	Aggregate, compl. Replaced by No. 292 35 67-00/8 in service	Agrégat,compl. Remplacable du No. 292 35 67-00/8 en service	Agregado, compl. Emplazamiento de No. 292 35 67-00/8 en servicio
292 31 51-00/1	Manöverpanel	Operating panel	Panneau de commande	Panel de mando
292 31 53-00/7	Gångled, övre	Hinge, upper	Charniere, superieure	Bisagra, superior
292 31 55-00/2	Fjäder	Spring	Ressort	Resorte
(292 31 56-00/0)	Kylfläns	Cooling flange	Eleent frigorifique	Elemento frigorifico
(292 31 57-00/8)	Droppskål	Drip tray	Bac d'égouttement	Bandeja goteo
(292 31 60-00/2)	Dekorlist, övre	Decoration strip, upper	Listeau décoration superieure	Liston decoración, superior
(292 31 61-00/0)	Dekorlist, undre	Decoration strip, lower	Listeau décoration inférieure	Listón decoracion, inferior
(292 31 62-00/8)	Slang	Hose	Tube flexible	Manguera
(292 31 63-00/6)	Hylla för islåda	Shelf for ice-tray	Clayette pour	Reprisa para
292 31 64-00/4	Ljusledare	Light conductor	Conducteur de lumière	Conductor de luz
292 31 65-00/1	Fjäder	Spring	Ressort	Resorte
291 31 66-00/9	Hållare	Retainer	Support	Retenedor
292 31 67-00/7	Dörr, kompl.	Door, compl.	Porte, compl.	Puerta, compl.
292 31 68-00/5	Flaskhållare	Bottle retainer	Porte de bouteilles	Porta de botellas
292 31 70-00/1	Dörrlist, undre	Door strip, lower	Listeau de porte, inférieure	Listón de puerta, inferior
292 31 71-00/9	Bussning	Bushing	Coussinet	Buje
292 31 72-00/7	Transportsäkring	Lock pin	Goupille d'arrêt	Pasador de cierre
292 31 73-00/5	Aggregat, kompl. Ersatt av Nr 292 35 67-00/8 i service	Aggregate compl. Replaced by No. 292 35 67-00/8 in service	Agrégat, compl. Remplacable du No. 292 35 67-00/8 en service	Agregado, compl. Emplazamiento de No. 292 35 67-00/8 en servicio
292 31 76-00/8	Lågspridare	Flue baffle	Distributeur de chaleur	Distribución de calor
292 31 77-00/6	Strömställare, svart	Switch, black	Interrupteur, noir	Interruptor, negro
(292 31 78-00/4)	Isoleringsplatta	Insulation plate	Plaque isolante	Placa aislante
292 31 80-00/0	Vred	Knob	Bouton	Perilla
292 31 81-00/8	Värmepatron 220/12V	Heater 220/12V	Cartouche 220/12V	Calentador 220/12V
292 31 83-00/4	Värmepatron 220V	Heater 220V	Cartouche 220V	Calentador 220V
292 31 84-00/2	Hållare	Retainer	Support	Retenedor
292 31 85-00/9	Bussning M10x1	Bushing M10x1	Coussinet M10x1	Buje M10x1
292 31 86-00/7	Gastilloppsrör	Gas inlet pipe	Conduite de gaz	Tube alimentador de gas
292 31 88-00/3	Gasanslutningsrör	Gas connection tube	Tube de connexion de gaz	Tube de conexion de gas

Part No. Pièce No.	Svenska Benämning	English Description	Français Désignation	Español Denominación
292 31 89-00/1	Mutter M15x1	Nut M15x1	Ecrou	Tuerca
292 31 90-00/9	Nippel	Nipple	Raccord	Racor
292 31 91-00/7	Filter	Filter	Filtre	Filtro
292 31 92-00/5)	Gasbrännare kompl. Ersätts av Nr. 292 3430-00/9 i service	Gas burner compl. Replaced by No. 292 3430-00/9 in service	Bruleur a gaz, compl. Remplacable du No. 292 3430-00/9 en service	Quemador de gas, compl. Emplazamiento de No. 292 3430-00/9 en servicio
292 31 93-00/3	Nippel	Nipple	Raccord	Racor
292 31 96-00/6	Vred	Knob	Bouton	Perilla
292 31 97-00/4	Tändkabel	Ignition cable	Câble d'allumage	Cable detonador
292 31 99-00/0	Dörrpanel	Door panel	Panneau de porte	Panel de puerta
292 32 90-00/7	Bussning	Bushing	Coussinet	Buje
292 32 92-00/3	Gångled, övre, höger och vänster	Hinge, upper, right and left	Charnière, supérieure droit et gauche	Bisagra, superior derecha y izquierda
292 33 20-00/2	Skål	Container	Recipient	Recipiente
292 33 21-00/0	Köldfackslucka, kompl. brun	Freezer door, compl. brown	Porte de congelateur, cpl brun	Puerta de congelador, compl. marron
292 33 22-00/8	Gångled undre	Hinge lower	Charnière inferieure	Bisagra inferior
292 33 23-00/6	Hylla, övre, vit	Shelf, upper, white	Clayette, superieure blanche	Anaqueel, superior blanco
292 33 24-00/4	Hylla, undre, vit	Shelf, lower, white	Clayette, inferieure, blanche	Anaqueel, inferior blanco
292 33 25-00/1	Hylla för islåda	Shelf for ice tray	Clayette pour boîte à glace	Repisa para gaveta para hielo
292 33 26-00/9	Fot	Foot	Pied	Pie
292 33 27-00/7	Manöverpanel	Operating panel	Panneau de commande	Panel de mando
292 33 28-00/5	Skylt	Plate	Plaque	Lamina
292 33 29-00/3	Vred	Knob	Bouton	Perilla
292 33 30-00/1	Värmepatron 220V, 105W	Heater 220V, 105W	Cartouche 220V, 105W	Calentador 220V, 105W
292 33 31-00/9	Värmepatron 12V, 105W	Heater 12V, 105W	Cartouche 12V, 105W	Calentador 12V, 105W
292 33 32-00/7	Gastilloppsrör	Gas inlet pipe	Conduite de gaz	Tubo de alimentador de gas
292 33 33-00/5	Gasanslutning	Gas connection	Connexion de gaz	Conexion de gas
292 33 34-00/3	Termostatratt	Thermostat knob	Bouton de thermostat	Botón de termostato
292 33 36-00/8	Flaskhållare	Bottle retainer	Porte de bouteilles	Porta de botellas
292 33 37-00/6	Äggållare	Egg support	Support d'oeufs	Soporte de huevos
(292 33 77-00/2)	Termostathållare	Thermostat support	Support/Thermostat	Soporte/Termostato
292 33 78-00/0	Axel	Shaft	Arbre	Eje
292 33 79-00/8	Termostatratt	Thermostat knob	Bouton de thermostat	Botón de termostato
(292 33 84-00/8)	Isoleringsplatta	Insulating plate	Plaque isolante	Placa aislante
292 34 27-00/5	Regel	Latch	Fermeture	Pestillo
292 34 28-00/3	Hylsa	Sleeve	Douille	Manguito
292 34 29-00/1	Skruv M6x6	Screw M6x6	Vis M6x6	Tornillo M6x6
292 34 30-00/9	Gasbrännare kompl.	Gas burner compl.	Bruleur a gaz, compl.	Quemador de gas compl.
(292 34 31-00/7)	Gasbrännare kompl.	Gas burner compl.	Bruleur a gaz, compl.	Quemador de gas, compl.
292 34 35-00/8	Termoelement. Ersätter Nr. 292 3187-00/5 i service	Thermo couple. Replace No. 292 3187-00/5 in service	Thermoelement. Remplace No. 292 3187-00/5 en service	Termoelemento. Reemplaza No. 292 3187-00/5 en servicio
292 34 53-00/1	Hylla, undre, vit	Shelf, lower, white	Clayette, inferieure, blanche	Repisa, inferior, blanca
292 34 64-00/8	Nippel. Ersätter Nr. 292 35 31-00/4 i service	Nipple. Replace No. 292 35 31-00/4 in service	Raccord. Remplace No. 292 35 31-00/4 en service	Racor. Reemplaza No. 292 35 31-00/4 en servicio
292 34 65-00/5	Strömställare	Switch	Interrupteur	Interruptor
(292 34 66-00/3)	Kopplingsplint	Terminal board	Plaque de connexion	Bloque de conexion
(292 34 67-00/1)	Isoleringsplatta	Insulating plate	Plaque isolante	Placa aislante
292 34 68-00/9	Termostatratt	Thermostat knob	Bouton de thermostat	Botón de termostato
292 35 22-00/3	Manöverpanel	Operating panel	Panneau de commande	Panel de mando
292 35 24-00/9	Dörr, kompl.	Door, compl.	Porte, compl.	Puerta, compl.
292 35 25-00/6	List, undre	Strip, lower	Listeau, inferieure	Liston, inferior
292 35 26-00/4	Gångled, övre, höger	Hinge, upper, right	Charnière, superieure, droit	Bisagra, superior, derecha
292 35 27-00/2	Gångled, undre, höger	Hinge, lower, right	Charniere, inferieure, droit	Bisagra, inferior, derecha
292 35 28-00/0	Aggregat, kompl.	Aggregate, compl.	Agrégat, compl.	Agregado, compl.
292 35 29-00/8	Värmepatron 220V, 95W	Heater 220V, 95W	Cartouche 220V, 95W	Calentador 220V, 95W
292 35 32-00/2	Tätningbricka	Sealing washer	Rondelle d'étanchéité	Arandela de junta
(292 35 58-00/7)	Bricka för kylfläns	Washer for cooling flange	Rondelle pour element frigorifique	Arandela para elemento frigorifico
292 35 67-00/8	Aggregat, kompl.	Aggregate, compl.	Agrégat, compl.	Agregado, compl.
292 35 84-00/3	Värmepatron 220V	Heater 220V	Cartouche 220V	Calentador 220V
292 36 21-00/3	Gångled, undre, vänster	Hinge, lower, left	Charnière, inferieure, gauche	Bisagra, inferior izquierda
292 36 22-00/1	Gångled, övre, vänster	Hinge, upper, left	Charnière, superieure, gauche	Bisagra, superior, izquierda

Det.nr. Part No. Pièce No. Parte No.	Svenska, Benämning	English Description	Français Désignation	Español Denominación
292 36 24-00/7	Manöverpanel	Operating panel	Panneau de commande	Panel de mando
292 36 26-00/2	Tändstift	Spark plug	Bougie	Bujia
292 36 27-00/0	Skylt	Plate	Plaque	Lamina
292 36 28-00/8	Ljusledare	Light conductor	Conducteur de lumière	Conductor de luz
292 36 29-00/6	Kåpa	Cover	Enveloppe	Cubierta
292 36 30-00/4	Dörr, kompl.	Door, compl.	Porte,compl.	Puerta, compl.
292 36 61-00/9	Dörr, kompl.	Door, compl.	Porte,compl.	Puerta,compl.
292 36 62-00/7	Hylla, övre	Shelf, upper	Clayette,superieure	Repisa,superior
292 38 49-00/0	Bussning	Bushing	Coussinet	Buje